

WATER STORAGE TANKS ARE UNDER WARRANTY FROM THE DATE OF PURCHASE AGAINST MANUFACTURING DEFECTS ONLY, ON VALID AND ORIGINAL GST INVOICE.

TERMS & CONDITIONS

- The warranty excludes damage caused by improper tank storage, installation, loading, and unloading, as well as damage sustained during in-transit handling.
- Warranty and liability are limited in nature and extends only to Manufacturing Defects.
- No coverage for changes in colour, including fading, discoloration, or loss of gloss. These may occur due to environmental exposure and do not affect the functional performance of the product.
- The warranty shall apply only to the first purchaser of the Water Tank and may be extended to the legal heir(s) of such purchaser, subject to submission of valid documentary proof of heirship.
- Claim requires Original Warranty Card and GST Invoice.
- Components or accessories are not covered under the warranty.
- No coverage for consequential, incidental, or associated losses or expenses.
- No coverage for Cracks, dents, or other physical damage caused by impact, misuse, or external forces.
- In the event of a disagreement between the purchaser and the company about the workmanship and performance of the water tanks, the company's decision shall be final.
- The total liability under this Warranty will never exceed the net ex-works value of any faulty or failed water tanks discovered within the Warranty term.
- Legal jurisdiction: Ahmedabad Court
- Sintex reserves the right, at its sole discretion, to change, modify, add or remove portions of these Terms of Warranty, at any time without prior notice.

THE WARRANTY OR LIABILITY OF THE COMPANY IS EXPRESSLY EXCLUDED IN THE FOLLOWING SITUATIONS:

- Defects caused by flaws in the supporting structure, fittings, or other water tank attachments.
- Problems caused by environmental, climatic, or various factors other than those listed above.
- Water tanks are used to store liquids other than water.
- The water tank was not installed in accordance with the company's standard guidelines*. The company shall not be liable for any damage caused by improper installation.
- Water tank repairs performed by parties not authorised by the company
- Use of water tanks once a leak is discovered, as cracks/damage to the water tanks are certain to propagate due to further use.
- Use of water tanks at temperatures above 60° Celsius.
- Using water tanks under pressure or vacuum.
- Use of water tanks for the transportation of water or any other liquid/substance or commercial activities.

*Please contact Toll Free 1800-121-2764 for installation guidelines and assistance.

FIG : 01 Threaded Adaptor Check Nut System (For hole sizes Below 2")

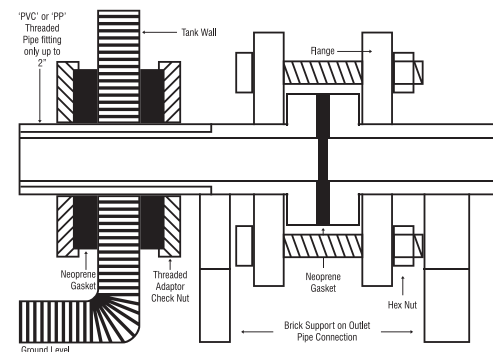
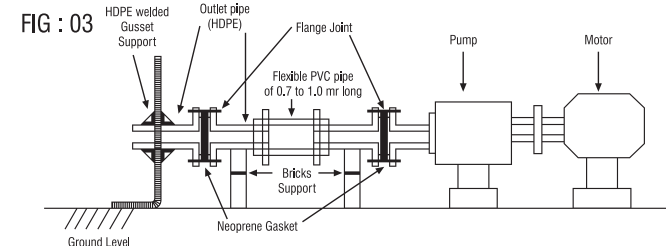
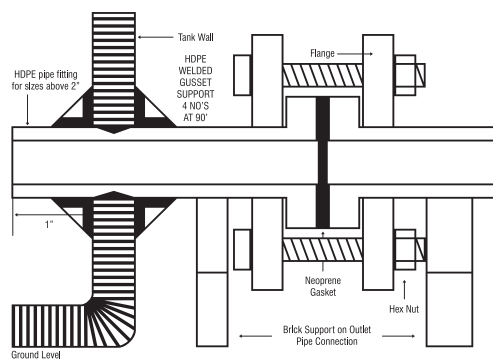

FIG : 02 Welded type fittings with gusset supports (For hole sizes above 2")



Typical schematic diagram of outlet pipe from the Water Storage Tank connected to the inlet pipe of the pump through an intermediate Flexible PVC Pipe

6 INTERCONNECTION OF TANKS

- We normally do not recommend interconnection of tanks. However, if you want to interconnect them, you should send all details and seek approval from us in writing. You should provide PVC flexible pipes in inlet and outlet areas of the tanks as shown in Fig. 4. Besides, you should first make a manifold of G.I. to which flexible pipes coming out of individual tank should be connected. If you desire to isolate individual tank for cleaning or maintenance, a valve in the pipe connecting manifold and individual tank should be provided.
- In case of size variation between Flexible pipe and connecting pipe, suitable size reducer shall be used for connection between Flexible pipe and Connecting pipe.

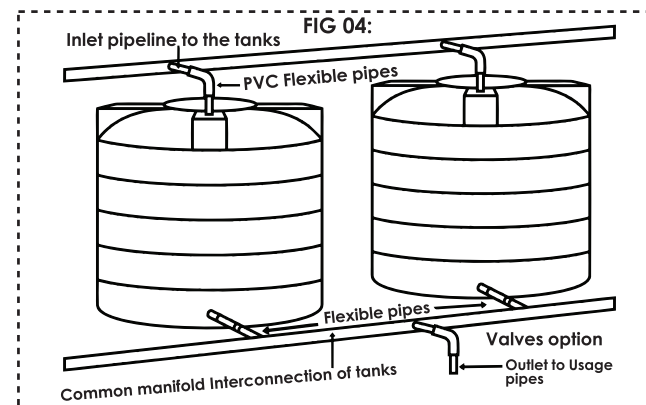

7 LOCATION OF USE

Sintex containers and tanks in black colour are made from UV Stabilised polyethylene. They can be used for both indoor and outdoor applications. Sintex Containers and Loft Tanks in white colour should be strictly used away from sun rays, as exposure to the sun will result in premature failure of the tank. You have to ensure that the lid of the tank is always kept closed.

8 TEMPERATURE OF USE

The normal service temperature in Sintex tanks is from 10°C to 60°C. If you wish to use the tank at a temperature higher than 60°C, you have to take full responsibility for the damage that may occur.

9 PRESSURE AND VACUUM

Sintex containers and tanks are designed for use at atmospheric pressure with substances of specific gravity up to: 1. if any pressure and vacuum is involved, it will be totally at your risk. Likewise, if the specific gravity of the material to be stored is more than 1, you should seek confirmation before use from our Design Department at Kalol (N.G.).

10 ACTION TO BE TAKEN WHILE NOTICING LEAKAGE IN TANKS

Polyethylene is a visco-elastic material and any crack on the body of the tank propagates very fast under stress and hydrostatic pressure. We strongly advise you to immediately stop usage of the water tank, if leakage is noticed anywhere in the tank. It is essential for you to rectify the tank before putting it into use again. Please contact your nearest Sintex branch office for rectification or contact our customer care. If this is not done, we shall not be responsible for further propagation and eventual failure of the tank.

11 IMPORTANT DO'S AND DON'TS

We are giving below some of the important DO's and DON'Ts which will help you in getting better performance from our tanks. You should strictly follow all the guidelines as given above.

DO'S

- Provide flat and full bottom support to the tank prior to installation.
- Keep the lid closed all the time.
- Install the tank on rigid, plain and smooth surface.
- Support all the connections to avoid torque on the area of fittings.
- Check all the connections for stress before using the tank. Fill up the tank step by step, i.e. 1/3 - 1/3 - full. (For fast filling)
- Maintain service temperature between 10°C and 60°C. Stop use of the tank if leakage is noticed and contact our customer care.
- If the tank has to be provided with more than one outlet holes, then holes should be drilled at 90° to each other just below the top pockets.
- In Reno tanks, maximum 2 outlet holes can be provided at 180° to each other at specified places.
- Provide appropriate airvent connection to the tank.

DON'Ts

- DO NOT make more than one outlet hole from the same place / adjoining each other.
- DO NOT install the tank on a rough surface.
- DO NOT install the tank near areas of vibration.
- DO NOT use connections of sizes bigger than recommended in table "A".
- DO NOT use the tank at pressure or vacuum.
- DO NOT make direct connections of the pump to the tank. Provide flexible pipe in-between.
- DO NOT directly interconnect two tanks. Interconnect through common manifold with flexible pipe in-between as shown in Fig. 4.

Note:

1. Sintex is not responsible for failure of the tank if it has not been installed as per adherence to the company guidelines given in this manual.
2. Sintex is not responsible for any collateral damage that occurs due to failure of the product for any reason.

Welspun®

Sintex Eterno™
50 YEAR WARRANTY

INSTALLATION MANUAL

FOR ADDED WARRANTY COVERAGE FROM DAMAGES DUE TO IMPROPER INSTALLATION, WE RECOMMEND THAT THE INSTALLATION OF YOUR SINTEX WATER STORAGE TANK IS DONE BY SINTEX SERVICE PERSONNEL

Applicable on 5000 and above liters on chargeable basis.



1800 121 2764 | www.sintexonline.com

Size: 19"x7"
Closed Size: 3.8"x7"

The optimum performance from Sintex tanks can be derived only by strictly adhering to the following guidelines for installation:

1 MOVEMENT OF THE TANK FROM THE PLACE OF RECEIPT TO THE PLACE OF INSTALLATION

Once you have received the tank in your stores or godown, you have to move it to the place of use which could be either of the following: (1) Top of the building (2) Interior of the building (3) Field.

When you have to take the tank to the top of the building, you will have to first ascertain whether it can be taken through your staircase. In most of the cases, the small capacity tank, say up to 500 litres, can be easily carried through the normal space available in a staircase.

A. The tank should be lifted appropriately and not dragged or rolled. If it is not possible, the tank will have to be lifted to the rooftop. A smaller capacity tank of up to 2000 litres can be lifted by two people easily.

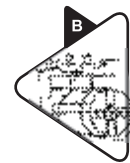

B. With proper lifting rope, ensure that the tank is fully supported. For bigger capacity tanks, it will be necessary for you to use a simple pulley to hoist the tank.

C. Ensure the tank does not have any stress. While it is being lifted, you have to put a protective sheet or hessian or some other locally available material around the tank so that there is very little possibility of abrasion on the sides of the tank.

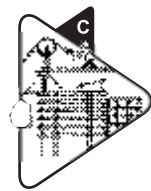

D. When the tank is to be installed for the field application, you can move the tank either by a mechanised or a manually operated vehicle. However, if you propose to roll the tank on the ground, do not forget to wrap a protective sheet around it so that there is very little chance for abrasion on the sides of the tank.

E. Rolling of the tank on an uneven or rough surface is to be avoided.

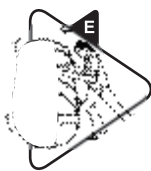

2 SUPPORT STRUCTURE

Sintex tanks from Series CCWS* i.e. for Sintex ISI, Sintex Neo, Sintex Black, Sintex White & Sintex TruPUF / WSCC* i.e. for Sintex Reno / IWS* i.e. for Sintex Loft / HSWS* i.e. for Sintex Pure / CSWS* i.e. for Sintex Tatva & Sintex Pure+ / ESWS* i.e. for Sintex Hero are self-supporting, provided they have full bottom support. The tanks from Series THWS (Tank Horizontal Water Storage) require full bottom support structure. Failures arising out of improper or wrong fabrication of the support structure will be totally to your account. The support structure drawing can be provided on your demand.



3 PROVISION OF OUTLET HOLES ON SINTEX TANKS (Refer QR code pasted at the bottom of the tank for a detailed video.)

The drilling of outlet holes on Sintex Tanks should be carried out strictly as under: These holes should be drilled perfectly circular and properly finished on the drilled edges to avoid any jagged edges or minor cracks. Holes up to 2' dia are drilled using a suitable size multisaw cutter. If holes are made without using multisaw cutters, then it may entail formation of cracks and the Warranty will not cover such cases. Holes of size above 2' and up to 3' should be drilled as under:

A. Determine the size of the hole 'Diameter' that you want to make. Determine the place where you want to make the hole. It must be 180° below the top pocket and at the centre of the tank side wall after the last rib.

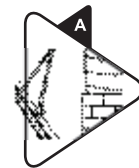

B. With the compass, mark the centre of hole 'C', which you want to make: Draw the circle of dia 'D*' on the surface of the tank taking the centre 'C' as marked above.

C. Determine the size of the hole 'd' which the ordinary hand drill in your possession can make. Draw another circle with centre 'C', but having a diameter less than the extent of the diameter of the hole which the hand drill can make 'D-d'.

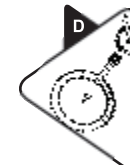
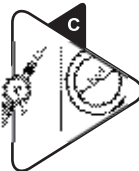

D. On the intermediate space between the two circles, make a series of holes close to each other.



E. Once the holes are made on the periphery of the inner circle, remove the plastic portion with the hand punch.



With the help of a hand file, now remove the redundant material remaining in the circumference of the outer circle. Ensure no notch is generated during removal of the redundant material.

Once you have smoothly finished the operation as mentioned above, you will have a hole of diameter 'D' as desired by you.

4 FITTINGS

- 4.1 Sintex tanks can be provided with 2 different types of fittings.
 - i) Threaded Adaptor Check Nut System (Fig. 1).
 - ii) Welded type fittings with gusset supports (Fig. 2).
- 4.2 The Adaptor Check Nut system is recommended only up to 2' dia pipe connections and also only for Water Storage Tanks. These fittings are made of PVC or Polypropylene (PP) materials only.
- 4.3 The Welded Type of fittings are intended for Pipe Connection of above 2' dia. These fittings are manufactured out of HDPE material so as to be suitable for welding with Sintex tanks.
- 4.4 Table 'A' indicates the normal recommended size of pipe fittings to be provided depending upon the capacity of the tanks.
- 4.5 (a) Warranty will be null & void if the outlet holes drilled are bigger in size than mentioned in the Table 'A'. (b) Warranty will be null & void if the outlet holes drilled are more than the number mentioned under the Table 'A'.

Table 'A':

Tank capacity-wise size of pipe fitting to be provided on the tanks. Max 2 Nos. outlet holes can be allowed.

Sr. No.	Capacity of Tanks	Nominal bore size of pipe connections to be fitted to the tank <small>(At Inlet, Outlet, overflow and drain)</small>
01	Up to 500 Ltrs	12.5 mm (1/2")
02	Above 500 Ltrs and up to 1000 Ltrs	19.0 mm (3/4")
03	Above 2000 Ltrs and up to 2000 Ltrs	25.0 mm (1")
04	Above 2000 Ltrs and up to 5000 Ltrs	40.0 mm (1 1/2")
05	5000 Ltrs and above & below 10000 Ltrs a) Sintex ISI and Pure tanks b) Sintex non-ISI tanks e.g. Sintex/Reno Tanks	50 mm (2") 40.0 mm (1 1/2")
06	10000 Ltrs tanks a) Sintex ISI and Pure tanks b) Sintex non-ISI tanks e.g. Sintex/Reno Tanks	63 mm (2 1/2") 50 mm (2")
07	Above 10000 Ltrs and up to 25000 Ltrs	75 mm (3")
a)	Sintex ISI tanks	75 mm (3")
b)	Sintex non-ISI 15000 Ltrs tanks	63 mm (2 1/2")
c)	Sintex non-ISI tanks above 15000 Ltrs tanks	75 mm (3")

Note:

With respect to Sintex Tank Installation for using different fittings / connections other than the sizes mentioned in above table, a written approval from the SINTEX R&D and QA Team will be required. Warranty will be null and void if the hole drilled is bigger than the size mentioned in above table, and if the fittings / connections are used without written approval of SINTEX R&D and QA Team.

5 CONNECTION OF FITTINGS TO THE TANK

- The connection of the threaded adaptor system is carried out duly ensuring that the wall of the tank is surrounded on either side by suitable rubber gaskets and the 2 check nuts are then tightened on the two sides of the wall of the tank to securely connect the fittings with the gaskets to the tank as shown in Fig. 1.
- The connection of welded type fitting is carried out as under:
 - First, the portion of the HDPE fitting to be welded is prepared properly with 'V' groove on its circumference.
 - The outlet/inlet holes on the tank where the fitting has to be welded is also prepared suitably in 'V' shape for proper welding of the HDPE fitting to the tank.
 - The HDPE fitting is then inserted into the hole so as to protrude only for about 'W' inside the tank.
 - The 'V' groove made on the fitting is positioned with the corresponding 'V' shape made on the edge of the hole and the fitting is then fully welded to the tank all around its circumference. Then, in order to strengthen the weld joint further, 4 Nos. of HDPE gussets are welded between the fitting and the tank on the outside of the tank at 90° to each other as shown on Fig. 2.
- The pipe fittings are given brick support as shown to prevent the bending of fittings and avoid stress on fittings during operation, as most of the problems arise from fittings.

We request you to take note of the following points:

- After all the fittings have been made, ensure that they have proper support so that no load is allowed to come on the wall of the tank.
- Check whether the welded fittings are welded with gusset supports or not.
- Check for any leakages from fittings before using the tank.
- Avoid direct connection of water pump to the tank.
- The size of the fittings should not exceed the size recommended in table 'A' unless agreed otherwise by our Quality Department at Kalol (N.G.).
- The whole pipeline connected to the tank should be well supported.
- For pipe connection of size 1" and above, provide a PVC flexible piping of 0.7 mtr to 1.0 mtr length in between the outlet piping from the tank and the inlet piping to the pump as shown in Fig. 3 to prevent any excessive vibrations from the pump being passed on to the tank outlet side.
- Install the tank away from areas with vibrations.
- Avoid interconnection of tanks as far as possible. If it is essential, use flexible pipe in between the tanks for interconnection as shown in Fig. 4.
- Keep minimum 64 feet gap in between two tanks during installation.
- Install the tanks on a rigid, plain and smooth surface.

Welspun®

Sintex Eterno™
50 YEAR WARRANTY

WARRANTY CARD*

Effective from 1st January 2026

Fill up the details in this card and keep it with you. You need to show/provide this card at the time of Warranty Claim, if any.

Customer's Name:

Address :

Model :

Product Code :

Colour :

Date of Purchase :

Distributor's Name:

Customer's Name:

Address (STAMP) [.....]

I certify that we have gone through the terms and conditions in the warranty card and accept them in totality.

WATER STORAGE TANKS ARE UNDER WARRANTY FROM THE DATE OF PURCHASE AGAINST MANUFACTURING DEFECTS ONLY, ON VALID AND ORIGINAL GST INVOICE.

Sintex-BAPL Limited

H.O.: Kalol, North Gujarat-382 721 India

Ph.: 02764 253 500

E-mail: sintex_support@welspun.com | Toll Free No.: 1800-121-2764

welspun.com | sintexonline.com